

View without upper protection covers
Ansicht ohne obere Schutzabdeckungen

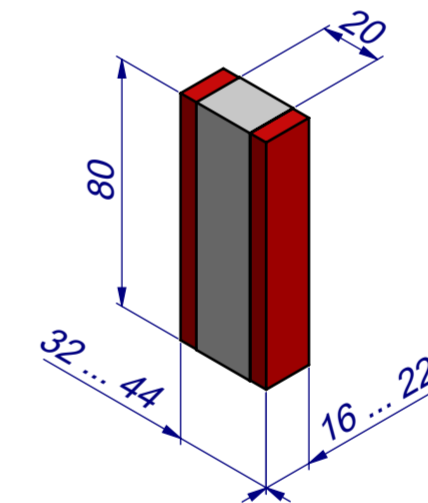
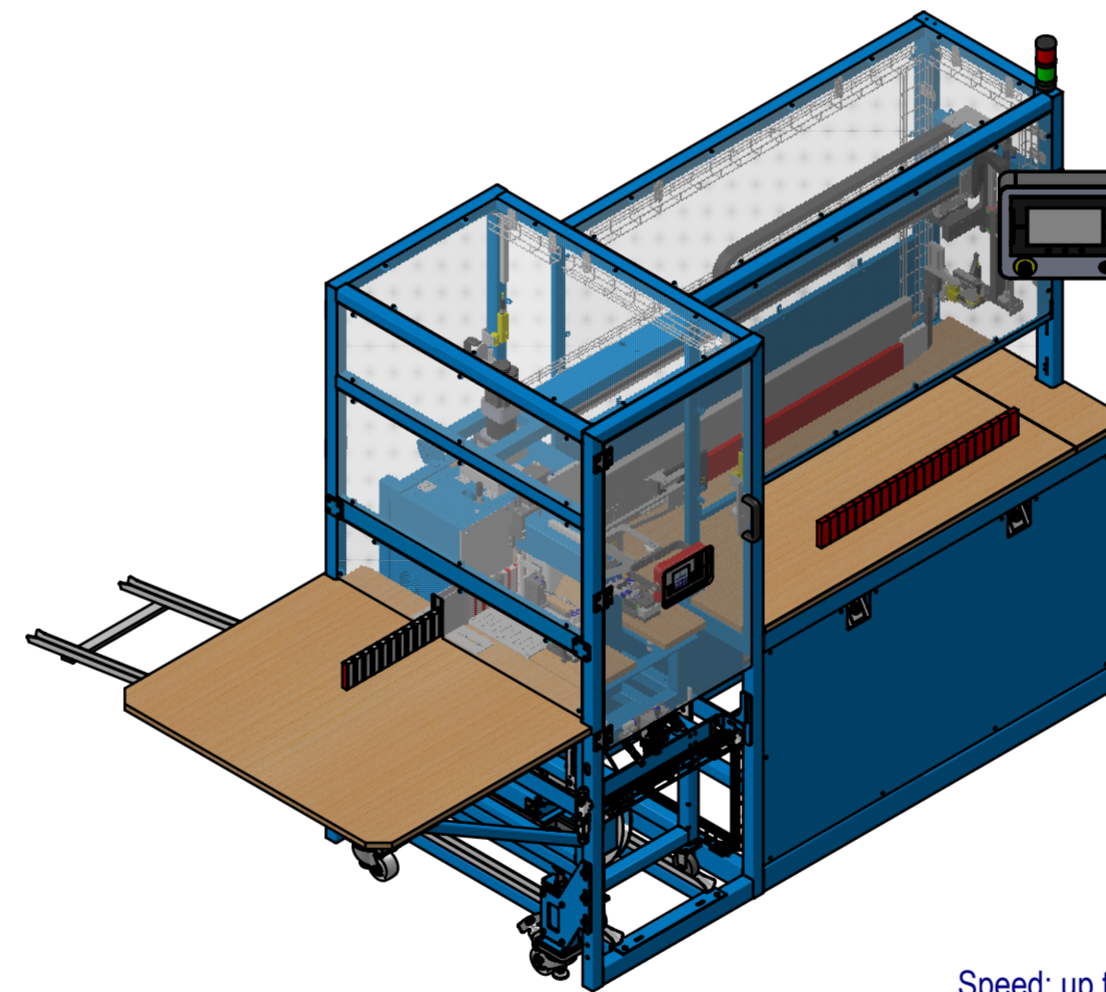
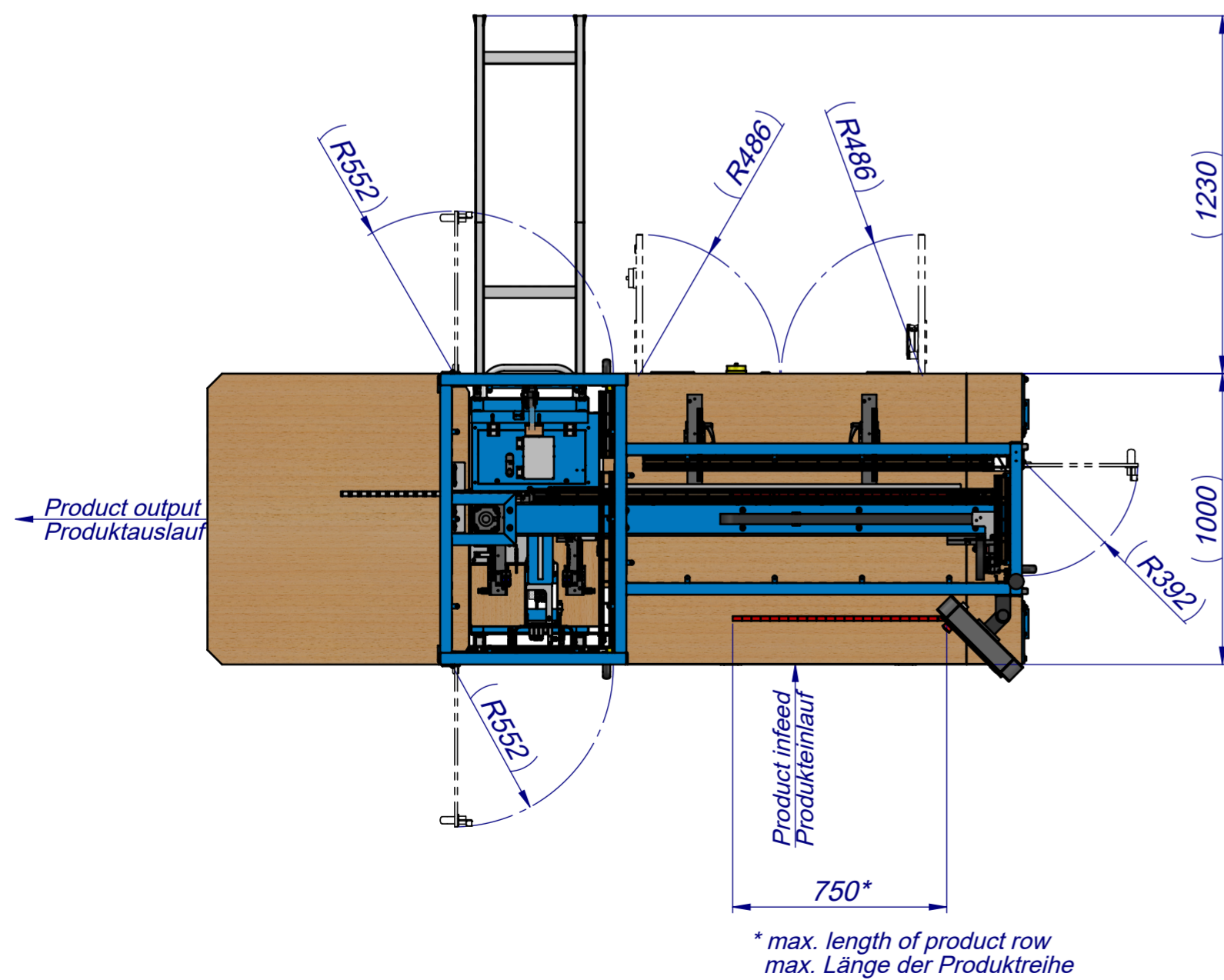

Speed: up to 20 cycles / min dependent on products and infeed
Pneum. connection: 6 bar
Electr. connection: 200-240 V ~ 50-60 Hz
Color: RAL 5012 (light blue)

Subject to change without notice

Leistung: bis 20 Takte / min je nach Produkt und Einlauf
Pneum. Anschluss: 6 bar
Elektr. Anschluss: 200-240 V ~ 50-60 Hz
Farbe: RAL 5012 (lichtblau)

Änderungen vorbehalten

Approved by customer

Name:.....
Date:.....
Signature:.....

Vom Kunden genehmigt

Name:.....
Datum:.....
Unterschrift:.....

US-2000 LBM-V Banderolieranl. 20mm
US-2000 LBM-V Banding system 20mm
Teile Nr.: 730107

Massstab	Gezeichnet	RST	08.02.2022
1:20	Geprüft	RST	18.03.2022
Status	Freigegeben		

Ursprungslayout: 0-730049-00
Zusammenstellung: 73 221154
Konstruktionslayout: KL-73 221154



CH-6300 Zug
Switzerland



Zeichnungsnummer :
KL-73 221154

Index
-

Blatt 1 von 1

Format A2